

DIN 71752 thread according to ISO 8140 CETOP for pneumatic cylinders

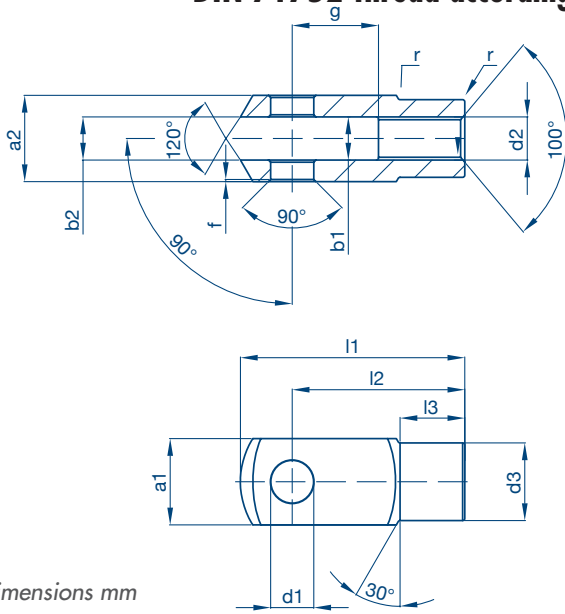

Series
G/FG
INOX

CLEVISES
STAINLESS STEEL Version

Dimensions mm

| DESIGNATION | CYLINDER Ø | d1 | g | a1 | a2 | b1 | b2 | d2 | d3 | f | l1 | l2 | l3 | r | static load Co.(daN) | weight ≈ (kg) | | | | |
|----------------|---------------|----|------|-----|--------------|-----|----|----------|----------|------|------|----|------|------|----------------------------|---------------------|----|----|------|-------|
| | | H9 | ±0,5 | h11 | 0,3 -0,16 | B13 | | 6H | ±0,3 | ±0,2 | ±0,5 | | Tol. | ±0,2 | | | | | | |
| G4X8 INOX | 8-10 | 4 | 8 | 8 | 8 | 4 | 4 | M4x0,70 | 8 | 0,5 | 21 | 16 | 6 | 0,5 | 320 | 0,005 | | | | |
| G6X12 INOX | 12-16 | 6 | 12 | 12 | 12 | 6 | 6 | | M6x1,00 | 10 | 0,5 | 31 | | | | | 24 | 9 | 720 | 0,015 |
| G8X16 INOX | 20 | 8 | 16 | 16 | 16 | 8 | 8 | | M8x1,25 | 14 | 0,5 | 42 | | | | | 32 | 12 | 1280 | 0,036 |
| G10X20 FG INOX | 25-32 | 10 | 20 | 20 | 20 | 10 | 10 | M10x1,25 | 18 | 0,5 | 52 | 40 | 15 | 0,5 | 2000 | 0,070 | | | | |
| G12X24 FG INOX | 40 | 12 | 24 | 24 | 24 | 12 | 12 | | M12x1,25 | 20 | 0,5 | 62 | | | | | 48 | 18 | 2880 | 0,121 |
| G16X32 FG INOX | 50-63 | 16 | 32 | 32 | 32 | 16 | 16 | | M16x1,50 | 26 | 1 | 83 | | | | | 64 | 24 | 5120 | 0,250 |

Similar to DIN 71752 (measures not included in the standard)

| DESIGNATION | CYLINDER Ø | d1 | g | a1 | a2 | b1 | b2 | d2 | d3 | f | l1 | l2 | l3 | r | static load Co.(daN) | weight ≈ (kg) | | | | |
|----------------|---------------|----|------|-----|----|-----|------|----------|----------|------|------|-----|------|-----|----------------------------|---------------------|-----|----|-------|-------|
| | | H9 | ±0,5 | h11 | | B13 | Tol. | 6H | ±0,3 | ±0,2 | ±0,5 | | ±0,2 | | | | | | | |
| G20X40 FG INOX | 80-100 | 20 | 40 | 40 | 40 | 20 | 20 | M20x1,50 | 34 | 1 | 105 | 80 | 30 | 1,5 | 8000 | 0,550 | | | | |
| G30X54 FG INOX | 125 | 30 | 54 | 55 | 55 | 30 | 30 | | M27x2,00 | 48 | 1 | 148 | | | | | 110 | 38 | 12500 | 1,460 |
| G35X72 FG INOX | 160-200 | 35 | 72 | 70 | 70 | 35 | 35 | | M36x2,00 | 60 | 1 | 188 | | | | | 144 | 40 | 24500 | 3,270 |

For left-hand thread add "LH" (ex. G16x32 FG LH INOX)
Technical reading from page 44 to page 45

MATERIAL

stainless steel (1.4305 - AISI 303)

chiavette unificate

